



ICC Evaluation Service, Inc.
www.icc-es.org

Business/Regional Office ■ 5360 Workman Mill Road, Whittier, California 90601 ■ (562) 699-0543
Regional Office ■ 900 Montclair Road, Suite A, Birmingham, Alabama 35213 ■ (205) 599-9800
Regional Office ■ 4051 West Flossmoor Road, Country Club Hills, Illinois 60478 ■ (708) 799-2305

Legacy report on the 1997 *Uniform Building Code*™

DIVISION: 07—THERMAL AND MOISTURE PROTECTION
Section: 07320—Roof Tiles

ONE-PIECE “S,” TAPERED TWO-PIECE MISSION, FLAT SHINGLE, ROMANO PANS, CLAYLITE® AND CLAYMAX® CLAY ROOFING TILES

UNITED STATES TILE COMPANY
909 RAILROAD STREET
CORONA, CALIFORNIA 92882-1906

1.0 SUBJECT

One-piece “S,” Tapered Two-piece Mission, Flat Shingle, Romano Pans, Claylite® and ClayMax® Clay Roofing Tiles.

2.0 DESCRIPTION

2.1 General:

The roofing tiles are a vitrified clay product, manufactured by United States Tile Company for use as a roof covering under the 1997 *Uniform Building Code*™ (UBC). The tiles are machine-formed, fired to various degrees and have a selection of burned-on colors. The various colors are obtained by controlled firing of the kilns. Tile profiles are illustrated in Figure 1.

The tiles may be installed on roof surfaces having slopes up to a maximum of 21:12 (175%). A solid sheathing conforming to the requirements of the UBC is required for all slopes.

2.2 Materials:

2.2.1 One-piece “S”-shaped Tile:

The finished tiles are 18 inches (457 mm) long, 13 inches (330 mm) wide and $\frac{1}{2}$ inch (12.7 mm) thick, with two nail holes in the pan side and one nail hole in the cover side. The installed weight of the tiles is approximately 8 pounds per square foot (39.1 kg/m²), and the tiles are designed for installation with an 11-inch (279 mm) center-to-center spacing and a minimum 3-inch (76 mm) head lap.

2.2.2 Tapered Two-piece Mission Tile: The finished tiles are 18 inches (457 mm) long, curved to approximately one third of a circle, and have a chord width of $8\frac{1}{2}$ inches (216 mm) at the butt end and 7 inches (178 mm) at the smaller end. The tiles have an average thickness of $\frac{1}{2}$ inch (12.7 mm) and an installed weight of approximately 9.6 pounds per square foot (46.9 kg/m²). They are designed for installation with 11-inch (279 mm) center-to-center spacing and a minimum 3-inch (76 mm) head lap.

2.2.3 Flat Shingle Tile: The finished tiles are 18 inches (457 mm) long, $9\frac{3}{4}$ inches (248 mm) wide and $\frac{9}{16}$ inch (14.3 mm) thick. There are three ribs on the underside of the tiles that are $\frac{1}{2}$ inch (12.7 mm) wide, and one rib at the lock that is 1 inch (25.4 mm) wide. Ribs are approximately 3 inches (76 mm) apart and run the full 18-inch (457 mm) length of the tile. Each tile has two nail holes in the top. Installed weight of the tiles is approximately $9\frac{1}{2}$ pounds per square foot (46.4 kg/m²). They are designed for installation with 9-inch (229 mm) center-to-center spacing and a minimum 3-inch (76 mm) head lap.

2.2.4 Romano Pans: The finished tiles are 18 inches (457 mm) long, 11 inches (279 mm) wide and $\frac{9}{16}$ inch (14 mm) thick, with two nail holes near the top of the pan. The completed installed weight of the tiles is approximately 9.9 pounds per square foot (48.3 kg/m²). They are designed for installation with two-piece Mission cover tiles with a 13-inch (330 mm) center-to-center spacing and a minimum 3-inch (76 mm) headlap.

2.2.5 Claylite Tile: The tiles are the same shape and size as one-piece “S”-shaped tiles. The finished tiles are 18 inches (457 mm) long, 13 inches (330 mm) wide and $\frac{3}{8}$ inch (9.5 mm) thick, with two nail holes in the pan side and one nail hole in the cover side. The installed weight of the tiles is approximately 5.9 pounds per square foot (28.8 kg/m²). They are designed for installation with an 11-inch (279 mm) center-to-center spacing and a minimum 3-inch (76 mm) headlap.

2.2.6 ClayMax Tile: The finished tiles are 18 inches (457 mm) long, 13 inches (330 mm) wide and $\frac{13}{32}$ inch (10.3 mm) thick, with two nail holes in the top. The installed weight of the tiles is approximately 5.8 pounds per square foot (28.3 kg/m²). They are designed for installation with an 11-inch (279 mm) center-to-center spacing and a minimum 3-inch (76 mm) head lap.

2.3 Installation:

2.3.1 General: Tiles shall be installed in accordance with the Concrete and Clay Roof Tile Installation Manual for Moderate Climate Regions (ESR-2015P), except as noted in this report.

2.3.2 Flat Shingle Tile: Rake tile or a full bed of mortar is provided under the exposed portion of each tile as a rake closure at the gable end. At hips and ridges, a Mission-type or a “V” type hip-and-ridge tile is set and nailed in cement mortar or roofers’ cement.

2.3.3 Claylite Tiles: Claylite tiles shall be fastened to the sheathing with two nails per tile. As an alternative, a single

nail, using the fastener hole located in the pan side $1\frac{3}{4}$ inch (44.3 mm) from the head end of the tile, may be used when the following conditions are met:

1. The roof slopes do not exceed 7:12 (58.3% slope).
2. Solid sheathing shall be not less than $\frac{7}{16}$ -inch (11.1 mm) oriented strand board or $\frac{15}{32}$ -inch (11.9 mm) wood structural panels.
3. The structure is located in an area designated by the building official as being subject to a maximum basic wind speed of 80 miles per hour (129 km/h), Exposure C, with the roof height up to 40 feet (12 192 mm) above grade.

2.3.4 ClayMax Tiles: ClayMax tiles shall be fastened to the sheathing with two nails per tile. As an alternative, a single nail, using the fastener hole located in the center, $1\frac{3}{4}$ inch (44.3 mm) from the head end of the tile, may be used when the following conditions are met:

1. The roof slope does not exceed 7:12 horizontal (58.3% slope).
2. Solid sheathing is not less than $\frac{7}{16}$ -inch (11.1 mm) oriented strand board or $\frac{15}{32}$ -inch (11.9 mm), four-ply, three-layer wood structural panels.
3. The structure is located in an area designated by the building official as being subject to a maximum basic wind speed of 80 miles per hour (129 km/h), Exposure C, with the roof height up to 40 feet (12 192 mm) above grade.

Installation details pertinent to the ClayMax tiles are as follows:

1. Hips and ridges are provided with continuous nominal 2-by-3 nailers to support ClayMax trim tiles.
2. Continuous nailers along the gable rakes are not required.

2.3.5 Tile Repair: The damaged tile is removed by breaking it completely out of the field and cleaning away all debris. Existing fasteners must be removed and the nail hole sealed with an approved sealant. Any damage to existing underlayment must be repaired prior to installation of the

replacement tile. The replacement tile is inserted into the open space, maintaining head and side laps. The tile is secured with approved plastic cement or adhesive, a No. 11 gage corrosion-resistant nail or an existing wire tie fastener.

2.4 Roofing Classification:

When installed over new construction as described in this report, the clay roof tiles are Class A roof coverings in accordance with Section 1504.1 of the UBC, and are noncombustible roof coverings in accordance with Section 1504.2 of the UBC.

2.5 Identification:

The letters "U.S.T." are embossed on the bottom of each tile near the nail hole on the cover side. Additionally, the tiles are identified by means of a tag attached to each shipping pallet bearing the evaluation report number (ER-3523) and the installed weight.

3.0 EVIDENCE SUBMITTED

Reports of tests conducted in accordance with the Acceptance Criteria for Clay and Concrete Roof Tiles (AC180), dated January 2002, installation instructions, and a quality control manual.

4.0 FINDINGS

That the One-piece "S," Tapered Two-piece Mission, Flat Shingle, Romano Pans, Claylite and ClayMax clay roofing tiles described in this report comply with the 1997 *Uniform Building Code*TM, subject to the following conditions:

- 4.1 The tiles are manufactured and installed in accordance with this report and the manufacturer's instructions.**
- 4.2 The tiles are manufactured at the United States Tile Company plant in Corona, California.**

This report is subject to re-examination in two years.

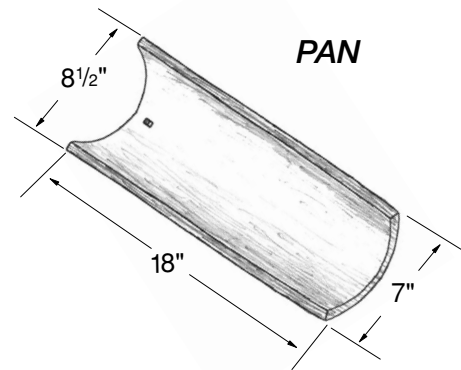
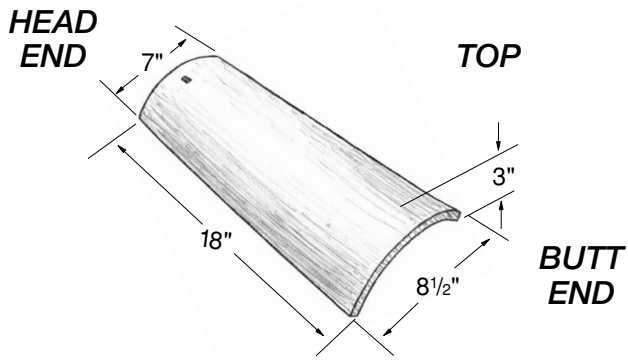

MISSION TWO-PIECE ROOF TILE

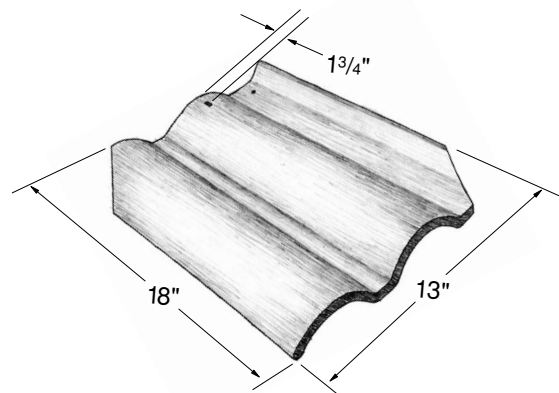
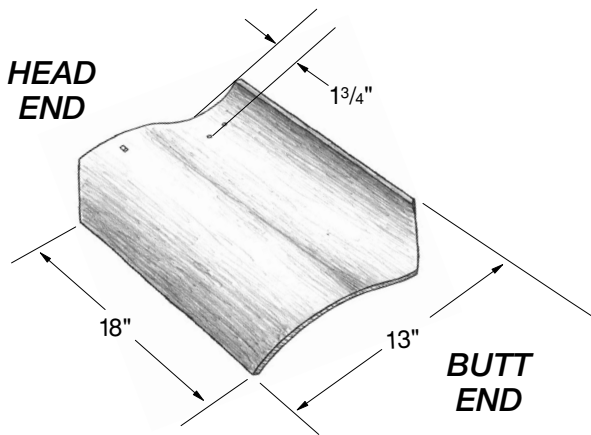

ONE-PIECE "S" AND CLAYLITE® ROOF TILE

CLAYMAX® ROOF TILE

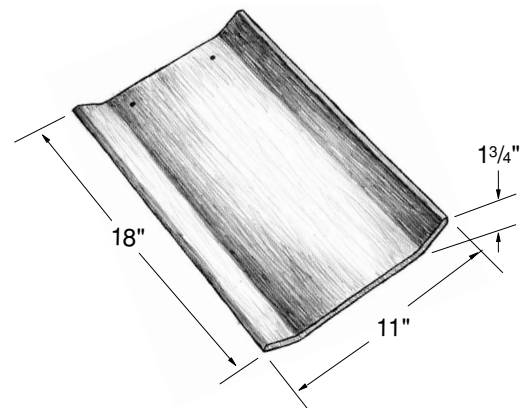
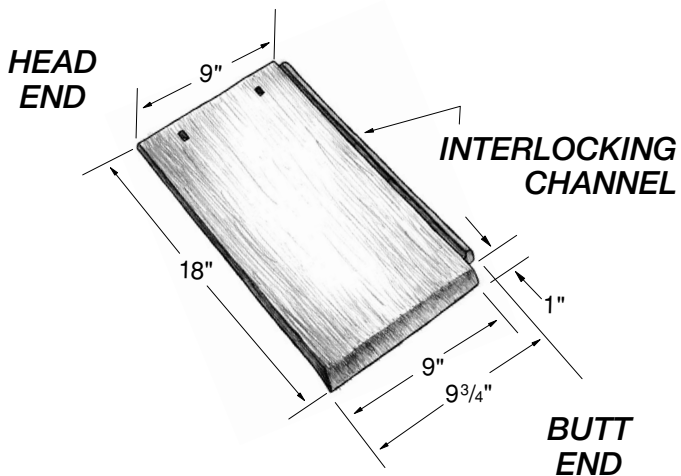

FLAT SHINGLE ROOF TILE

ROMANO® PAN

FIGURE 1—TILE PROFILES