

ICC-ES Evaluation Report

ESR-1017

Reissued December 1, 2010

This report is subject to re-examination in two years.

www.icc-es.org | (800) 423-6587 | (562) 699-0543

A Subsidiary of the International Code Council®

**DIVISION: 07 00 00—THERMAL AND MOISTURE
PROTECTION**
Section: 07 32 13—Clay Roof Tiles
REPORT HOLDER:
**UNITED STATES TILE COMPANY
909 RAILROAD STREET
CORONA, CALIFORNIA 92882-1906
(951) 737-0200
www.ustile.com**
EVALUATION SUBJECT:
**ONE-PIECE “S,” TAPERED TWO-PIECE MISSION,
MONARCH TWO-PIECE MISSION, ROMANO® PAN,
CLAYLITE®, CLAYMAX®, AND PROSHAKE CLAY ROOF
TILES**
1.0 EVALUATION SCOPE
Compliance with the following codes:

- 2006 *International Building Code*® (IBC)
- 2006 *International Residential Code*® (IRC)
- Other Codes (See Section 8.0)

Properties Evaluated:

- Weather resistance
- Fire classification
- Wind uplift resistance

2.0 USES

The clay roof tiles described in this report are Class A roof coverings in accordance with the exception to IBC Section 1505.2 and IRC Section R902.1.

3.0 DESCRIPTION
3.1 General:

The tiles are vitrified clay products, and are machine-formed and fired to various degrees and have a selection of burned-on colors. The various colors are obtained by controlled firing of the kilns. See Figure 1 for tile profiles and dimensions.

3.2 One-Piece “S” Tile:

The tiles are 18 inches (457 mm) long, 13 inches (330 mm) wide and $\frac{1}{2}$ inch (12.7 mm) thick, with two nail holes in the pan side and one nail hole in the cover side. The installed weight of the tiles is 8 pounds per square foot (39.1 kg/m²),

and the tiles are designed for installation with an 11-inch (279 mm) center-to-center spacing and a minimum 3-inch (76 mm) headlap. The tiles conform to the Grade 2 physical requirements of ASTM C 1167.

3.3 Tapered Two-Piece Mission Tile:

The tiles are 18 inches (457 mm) long, curved to approximately one-third of a circle, and have a chord width of $8\frac{1}{2}$ inches (216 mm) at the butt end and 7 inches (178 mm) at the smaller end. The tiles have an average thickness of $\frac{1}{2}$ inch (12.7 mm) and an installed weight of 9.6 pounds per square foot (46.9 kg/m²). They are designed for installation with 11-inch (279 mm) center-to-center spacing and a minimum 3-inch (76 mm) headlap. The tiles conform to the Grade 2 physical requirements of ASTM C 1167.

3.4 Monarch Two-Piece Mission Tile:

The tiles are 18 inches (457 mm) long, curved to approximately one-third of a circle, and have a chord width of $6\frac{3}{4}$ inches (171 mm) at the butt end and a chord width of $5\frac{1}{4}$ inches (133 mm) at the smaller end. The tiles have an average thickness of $\frac{1}{2}$ inch (12.7 mm). The installed weight is 10.7 pounds per square foot (52.3 kg/m²), when installation is with a 3-inch (76 mm) head lap and a 9-inch (229 mm) center-to-center spacing. One nail hole is provided at the top center of each tile. The tiles conform to the Grade 3 physical requirements of ASTM C 1167.

3.5 Romano Pan:

The tiles are 18 inches (457 mm) long, 11 inches (279 mm) wide and $\frac{9}{16}$ inch (14.3 mm) thick, with two nail holes near the top of the pan. The installed weight of the tiles is 9.9 pounds per square foot (48.3 kg/m²). They are designed for installation with Two-Piece Mission cover tiles with a 13-inch (330 mm) center-to-center spacing and a minimum 3-inch (76 mm) headlap. The tiles conform to the Grade 2 physical requirements of ASTM C 1167.

3.6 Claylite Tile:

The tiles are similar in shape and size to the One-Piece “S”-shaped tiles. The finished tiles are 18 inches (457 mm) long, 13 inches (330 mm) wide and $\frac{3}{8}$ inch (9.5 mm) thick, with two nail holes in the pan side and one nail hole in the cover side. The installed weight of the tiles is 5.9 pounds per square foot (28.8 kg/m²). They are designed for installation with an 11-inch (279 mm) center-to-center spacing and a minimum 3-inch (76 mm) headlap. The tiles conform to the Grade 3 physical requirements of ASTM C 1167.

3.7 ClayMax Tile:

The tiles are 18 inches (457 mm) long, 13 inches (330 mm) wide and $1\frac{3}{32}$ inch (10.3 mm) thick, with two nail holes in the top. The installed weight of the tiles is 5.8 pounds per square foot (28.3 kg/m²). They are designed for installation with an 11-inch (279 mm) center-to-center spacing and a minimum 3-inch (76 mm) headlap. The tiles conform to the Grade 2 physical requirements of ASTM C 1167.

3.8 ProShake Tile:

The ProShake tiles are 14 inches (356 mm) long, $8\frac{1}{2}$ inches wide (216 mm) and 1 inch thick (25 mm), with two nail holes at the head of the tile. Interlocking details at the head of the tile and on the left side provide for installation with a $2\frac{1}{4}$ -inch (57 mm) head lap and a 0.8-inch (20.32 mm) side lap. The installed weight of the tiles is 5.9 pounds per square foot (28.8 kg/m²). The tiles conform to the Grade 1 physical requirements of ASTM C 1167.

The tiles are manufactured in two different textures, identified as Profile A and Profile B.

4.0 INSTALLATION

4.1 General:

Except as otherwise noted in this report, installation must be in accordance with the Concrete and Clay Roof Tile Installation Manual for Moderate Climate Regions, published by the Tile Roofing Institute and the Western States Roofing Contractors Association (hereinafter referred to as the TRI/WSRCA installation manual), and recognized in ICC-ES [ESR-2015P](#). This report and the TRI/WSRCA installation manual must be available at the jobsite at all times during installation.

4.1.1 Claylite Tiles: Claylite tiles must be fastened to the sheathing with two nails per tile. As an alternative, a single nail, using the fastener hole located in the pan side $1\frac{3}{4}$ inches (44.3 mm) from the head end of the tile, may be used with the maximum allowable wind speed and roof height as shown in Table 1, for the zone and exposure as noted. Nails must be in accordance with IBC Table 1507.3.7 or IRC Section R905.3.6, as applicable. Solid sheathing must be not less than $\frac{7}{16}$ -inch (11.1 mm) oriented strand board or $\frac{15}{32}$ -inch (11.9 mm) wood structural panels. Nails must be minimum No. 11 gage [0.1196 inch (3.03 mm)] and have minimum $\frac{7}{16}$ -inch-diameter (11.1 mm) heads.

4.1.2 Claymax Tiles: ClayMax tiles must be fastened to the sheathing with two nails per tile. As an alternative, a single nail, using the fastener hole located in the center, $1\frac{3}{4}$ inches (44.3 mm) from the head end of the tile, may be used with the maximum allowable wind speed and roof height as shown in Table 2, for the zone and exposure as noted. Nails must be in accordance with IBC Table 1507.3.7 or IRC Section R905.3.6, as applicable. Solid sheathing must be not less than $\frac{7}{16}$ -inch (11.1 mm) oriented strand board or $\frac{15}{32}$ -inch (11.9 mm) wood structural panels. Nails must be minimum No. 11 gage [0.1196 inch (3.03 mm)] and have minimum $\frac{7}{16}$ -inch-diameter (11.1 mm) heads.

4.1.3 ProShake Tiles: ProShake tiles must be fastened to the sheathing in accordance with Table 3 of this report. In jurisdictions subject to snow, a minimum of two fasteners are required per tile. The roof deck must be minimum $\frac{7}{16}$ -inch-thick (11.1 mm) oriented strand board or $\frac{15}{32}$ -inch-thick (11.9 mm) plywood. Fasteners must have a minimum corrosion resistance of ASTM A 641 Class 1 and must be of sufficient length to penetrate $\frac{3}{4}$ inch (19 mm) into or through the thickness of the sheathing. Nails must

be minimum No. 11 gage [0.1196 inch (3.03 mm)] and have minimum $\frac{3}{8}$ -inch-diameter (9.1 mm) heads. Screws must be No. 8 flat head wood screws having a minimum 0.135-inch (3.43 mm) shank diameter and minimum 0.335-inch (8.51 mm) head diameter.

4.2 Adhesively Attached Systems:

The clay roof tiles may be installed with roof tile adhesives that are recognized in a current ICC-ES evaluation report for use in concrete roofing tile applications. Installation of tiles using these adhesive set systems must be in accordance with the adhesive manufacturer's ICC-ES evaluation report.

4.3 Roof Slope Limitation:

The roof tiles, except the ProShake tiles, must be installed on a minimum roof slope of $2\frac{1}{2}$:12 (20.83 percent). The ProShake tiles must be installed on a minimum roof slope of 3:12 (25 percent).

4.4 Roofing Classification:

When installed as described in this report, the roof tiles are Class A roof coverings in accordance with the exception to IBC Section 1505.2 and IRC Section R902.1.

4.5 Wind Resistance:

4.5.1 General: When installation is on roof slopes greater than 21:12 (175 percent), the noses of all tiles must be securely fastened.

4.5.2 High Wind Applications: For applications beyond the prescriptive parameters of IBC Section 1507.3.7 and IRC Section R905.3.7, the fastening systems must be determined to withstand the aerodynamic uplift moment in accordance with the Design Considerations for High Wind Applications in Appendix B of the TRI/WSRCA installation manual.

4.6 Reroofing Applications:

The tiles may be installed over existing roofs, provided the requirements of IBC Section 1510 and IRC Section R907, as applicable, are met. The roof classification is as noted in Section 4.4.

5.0 CONDITIONS OF USE

The clay roof tiles described in this report comply with, or are suitable alternatives to what is specified in, those codes listed in Section 1.0 of this report, subject to the following conditions:

- 5.1 The roof tiles are manufactured, identified and installed in accordance with this report, the TRI/WSRCA installation manual and the applicable code. If there is a conflict between this report and the installation manual, this report governs.
- 5.2 The roof sheathing and roof framing system must be designed for the appropriate loads determined in accordance with the applicable code, subject to the approval of the code official.

6.0 EVIDENCE SUBMITTED

Data in accordance with ICC-ES Acceptance Criteria for Clay and Concrete Roof Tiles (AC180), dated August 2007.

7.0 IDENTIFICATION

The letters "U.S.T." are embossed on the underside of each tile (except the ProShake tiles), near the nail hole. The ProShake tiles are embossed with the words "Boral US Tile ProShake Plus A or Boral US Tile ProShake Plus

B" on the underside of each tile. Additionally, a tag must be attached to each shipping pallet that bears the report holder's name (United States Tile Company) and address, the product name, the evaluation report number (ESR-1017) and the installed weight.

8.0 OTHER CODES

8.1 Evaluation Scope:

In addition to the codes referenced in Section 1.0, the products in this report were evaluated for compliance with the requirements of the 1997 *Uniform Building Code*[®] (UBC).

8.2 Uses:

The clay roof tiles described in this report are noncombustible roof coverings in accordance with UBC Section 1504.2.

8.3 Description:

See Section 3.0.

8.4 Installation:

8.4.1 General: See Section 4.1 except for the following:

Replace the language in Section 4.1.1 to read as follows:

Claylite Tiles: Claylite tiles must be fastened to the sheathing with two nails per tile. As an alternative, a single nail, using the fastener hole located in the pan side $1\frac{3}{4}$ inch (44.3 mm) from the head end of the tile, may be used when the following conditions are met:

- The roof slopes do not exceed 7:12 (58.3% slope).
- Solid sheathing must be not less than $\frac{7}{16}$ -inch (11.1 mm) oriented strand board or $\frac{15}{32}$ -inch (11.9 mm) wood structural panels.
- The structure is located in an area designated by the building official as being subject to a maximum basic wind speed of 80 miles per hour (129 km/h), Exposure C, with the roof height up to 40 feet (12 192 mm) above grade.

Replace the language in Section 4.1.2 to read as follows:

ClayMax Tiles: ClayMax tiles must be fastened to the sheathing with two nails per tile. As an alternative, a single nail, using the fastener hole located in the center, $1\frac{3}{4}$ inch (44.3 mm) from the head end of the tile, may be used when the following conditions are met:

- The roof slope does not exceed 7:12 horizontal (58.3% slope).
- Solid sheathing is not less than $\frac{7}{16}$ -inch (11.1 mm) oriented strand board or $\frac{15}{32}$ -inch (11.9 mm), four-ply, three-layer wood structural panels.

- The structure is located in an area designated by the building official as being subject to a maximum basic wind speed of 80 miles per hour (129 km/h), Exposure C, with the roof height up to 40 feet (12 192 mm) above grade.

Installation details pertinent to the ClayMax tiles are as follows:

- Hips and ridges are provided with continuous nominally 2-by-3 nailers to support ClayMax trim tiles.
- Continuous nailers along the gable rakes are not required.

Section 4.1.3 remains the same except that ProShake tiles must be fastened to the sheathing in accordance with Table 4 of this report.

8.4.2 Adhesively Attached Systems: See Section 4.2.

8.4.3 Roof Slope Limitation: See Section 4.3.

8.4.4 Roofing Classification: When installed as described in this report, the roof tiles are noncombustible roof coverings in accordance with UBC Section 1504.2.

8.4.5 Wind Resistance:

8.4.5.1 General: See Section 4.5.1.

8.4.5.2 High Wind Applications: For applications beyond the prescriptive parameters of UBC Section 1507.7, the fastening systems must be determined to withstand the aerodynamic uplift moment in accordance with the Design Considerations for High Wind Applications in Appendix B of the TRI/WSRCA installation manual.

8.4.6 Reroofing Applications: The tiles may be installed over existing roofs, provided the requirements of the Appendix to UBC Chapter 15 are met. The roof classification is as noted in Section 8.4.4.

8.5 Conditions of Use:

The clay roof tiles described in this report comply with, or are suitable alternatives to what is specified in the UBC, subject to the conditions noted in Section 5.0

8.6 Evidence Submitted:

See Section 6.0.

8.7 Identification:

See Section 7.0.

TABLE 1—MAXIMUM WIND SPEEDS (IBC AND IRC) FOR CLAYLITE TILES—ONE-FASTENER INSTALLATION

BUILDING HEIGHT (ft)	$7^{\circ} \leq \Omega \leq 27^{\circ}$	$7^{\circ} \leq \Omega \leq 27^{\circ}$	$27^{\circ} \leq \Omega \leq 45^{\circ}$	$27^{\circ} \leq \Omega \leq 45^{\circ}$
	ZONE 3 EXPOSURE B	ZONE 2 EXPOSURE B	ZONE 3 EXPOSURE B	ZONE 2 EXPOSURE B
20	91	124	137	137
40	87	119	132	132
60	N/A	112	124	124
	ZONE 3 EXPOSURE C	ZONE 2 EXPOSURE C	ZONE 3 EXPOSURE C	ZONE 2 EXPOSURE C
20	N/A	109	121	121
40	N/A	102	112	112
60	N/A	97	109	109

For SI: 1 foot = 304.8 mm; 1 mph = 1.61 km/h.

TABLE 2—MAXIMUM WIND SPEEDS (IBC AND IRC) FOR CLAYMAX TILES—ONE-FASTENER INSTALLATION

BUILDING HEIGHT (ft)	$7^{\circ} \leq \Omega \leq 27^{\circ}$	$7^{\circ} \leq \Omega \leq 27^{\circ}$	$27^{\circ} \leq \Omega \leq 45^{\circ}$	$27^{\circ} \leq \Omega \leq 45^{\circ}$
	ZONE 3 EXPOSURE B	ZONE 2 EXPOSURE B	ZONE 3 EXPOSURE B	ZONE 2 EXPOSURE B
20	105	142	157	157
40	100	136	151	151
60	95	129	142	142
	ZONE 3 EXPOSURE C	ZONE 2 EXPOSURE C	ZONE 3 EXPOSURE C	ZONE 2 EXPOSURE C
20	92	125	139	139
40	86	117	129	129
60	N/A	112	124	124

For SI: 1 foot = 304.8 mm; 1 mph = 1.61 km/h.

TABLE 3—MAXIMUM WIND SPEEDS (IBC AND IRC) FOR PROSHAKE TILES

SHEATHING	MINIMUM THICKNESS (in.)	FASTENER(S) ²	BUILDING HEIGHT (ft)	MAXIMUM BASIC (3-SECOND GUST) WIND SPEED			
				2.25-inch Headlap			
				Slope: 3:12 to 7:12		Slope: > 7:12	
				Exposure B ¹	Exposure C ¹	Exposure B ¹	Exposure C ¹
Plywood	15/32	1 screw	20	106	94	136	120
			40	102	87	130	111
			60	97	N/A	124	107
Plywood	15/32	2 screws	20	170	151	170	170
			40	164	140	170	170
			60	155	135	170	170
Plywood	15/32	1 nail	20	92	N/A	118	104
			40	88	N/A	113	96
			60	N/A	N/A	107	92
Plywood	15/32	2 nails	20	115	101	146	129
			40	110	94	141	120
			60	104	90	133	115
OSB	7/16	1 screw	20	117	103	149	132
			40	112	96	143	123
			60	106	92	136	118
OSB	7/16	2 screws	20	153	135	170	170
			40	147	126	170	160
			60	139	120	170	154
OSB	7/16	2 nails	20	87	N/A	111	98
			40	N/A	N/A	100	91
			60	N/A	N/A	101	88

For **SI**: 1 mph = 1.61 km/h, 1 inch = 25.4 mm, 1 foot = 304.8 mm.

¹Topographic effects, located in any exposure category, are designed in accordance with Section 6.5.7 of ASCE 7.

²See Section 4.1.3 for fasteners.

TABLE 4—MAXIMUM WIND SPEEDS (UBC) FOR PROSHAKE TILES

SHEATHING	MINIMUM THICKNESS (in.)	FASTENER(S) ¹	BUILDING HEIGHT (ft)	MAXIMUM BASIC (FASTEST MILE) WIND SPEED			
				2.25-inch Headlap			
				Slope: 3:12 to 7:12		Slope: > 7:12	
				Exposure B	Exposure C	Exposure B	Exposure C
Plywood	15/32	1 screw	20	115	89	130	105
			40	103	82	130	105
			60	92	76	118	97
Plywood	15/32	2 screws	20	130	130	130	130
			40	130	130	130	130
			80	130	122	130	130
Plywood	15/32	1 nail	20	99	77	127	98
			40	89	71	113	91
			80	80	N/A	102	84
Plywood	15/32	2 nails	20	124	96	130	122
			40	111	89	130	113
			80	100	82	130	105
OSB	7/16	1 screw	20	104	130	130	130
			40	96	121	127	123
			60	92	113	119	118
OSB	7/16	2 screws	20	130	128	130	130
			40	130	118	130	130
			80	130	110	130	130
OSB	7/16	2 nails	20	94	73	120	90
			40	84	N/A	107	86
			80	76	N/A	96	80

For **SI**: 1 mph = 1.61 km/h, 1 inch = 25.4 mm, 1 foot = 304.8 mm.

¹See Section 4.1.3 for fasteners.

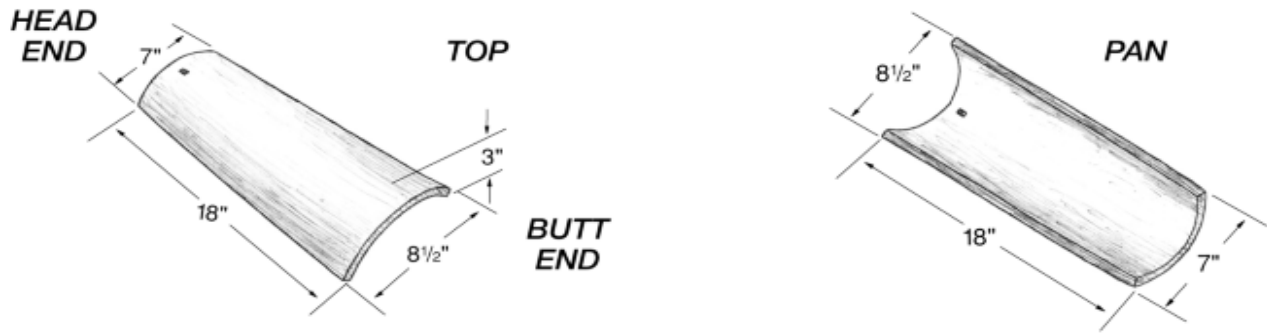

TAPERED TWO-PIECE MISSION ROOF TILE

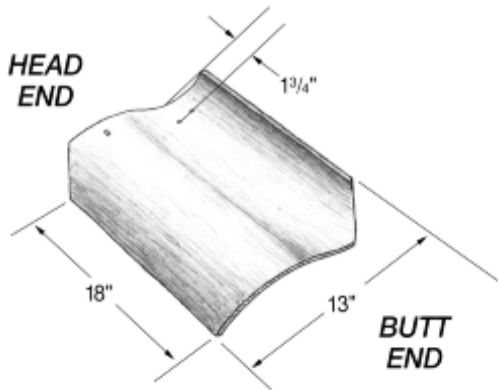

**ONE-PIECE "S" AND CLAYLITE®
ROOF TILE**

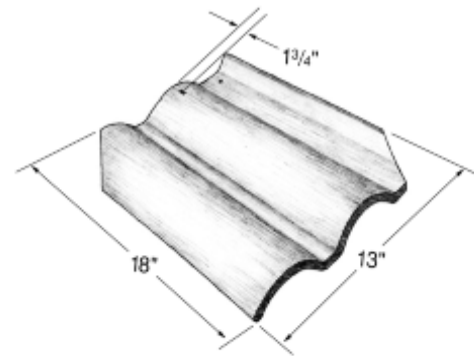

CLAYMAX® ROOF TILE

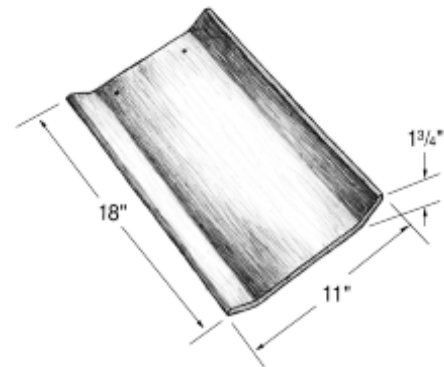

ROMANO® PAN

FIGURE 1—TILE PROFILES

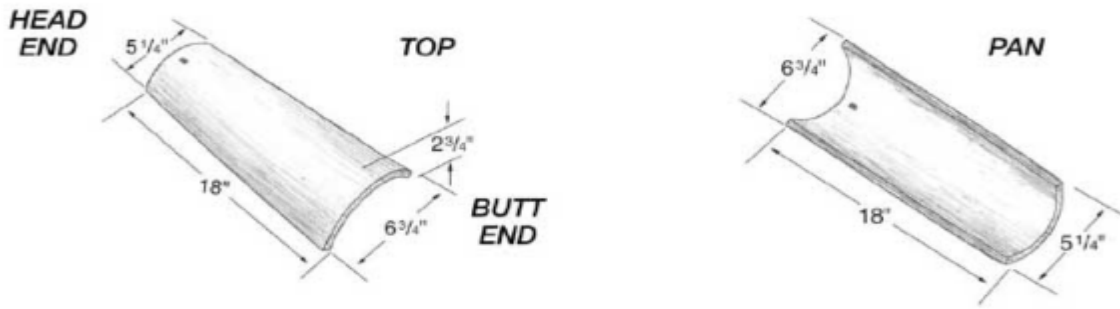

MONARCH TWO-PIECE MISSION ROOF TILE

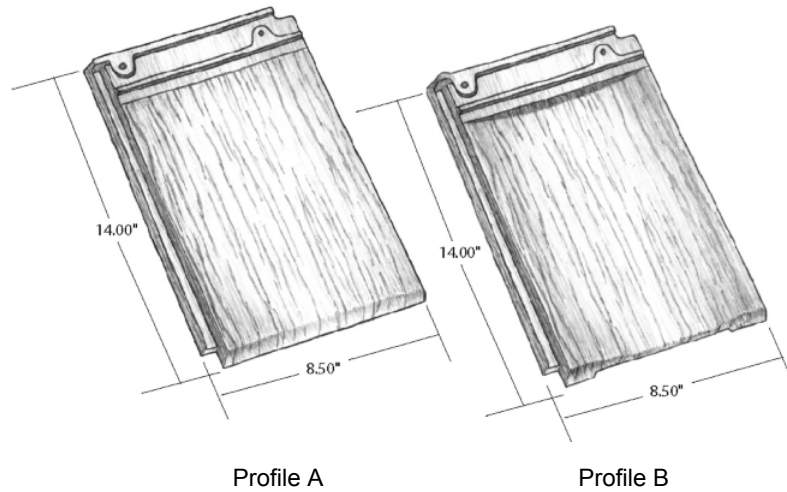

PROSHAKE TILE

FIGURE 1—TILE PROFILES (Continued)

For SI: 1 inch = 25.4 mm.